

## SPHERICAL TRANSPARENCY ILLUMINATOR LE6-100

### Serial no.



ill. 1

The spherical transparency illuminator LE6-100 is designed for illuminating test transparencies of all kinds that are used for testing and evaluating visual recording equipment, mainly electronic cameras. The transparency format is 360x280x4mm. When using other formats an adapter is necessary.

When the shutter is in an open position the illuminator does not reach higher temperatures, even if in use for many hours. Therefore it is not necessary to use the fan for ventilation. However, when working with very low light intensity, i.e. when the shutter is almost closed, we recommend to use the ventilation system.

### General information

The illuminator is working on the principle of an integrating sphere. It says that when using a sphere as hollow body with a homogeneous interior coating which completely diffuses the reflected light, the indirect lighting density is constant throughout the complete interior area. This also applies to a small measuring window in the sphere. When enlarging this window the homogeneity of the luminous density decreases. Although the transparency window is fairly large in relation to the overall size of the sphere the spherical illuminator LE6-100 shows an extremely homogeneous light density at its measuring window. The unevenness is 3-4% max., resp. 5% with extremely low light.

Therefore the unit may be used not only for conventional testing and evaluation but is particularly suited for precise measurements in research and development. It also meets the requirements that are stated in IEC 61146, „Videocameras (PAL-SECAM-NTSC)-Methods of measurement“ Parts 1-3 for transparency illuminators.



The device can be used as a table model (see ill.2) or be set on the tripod supplied (see ill. 1).

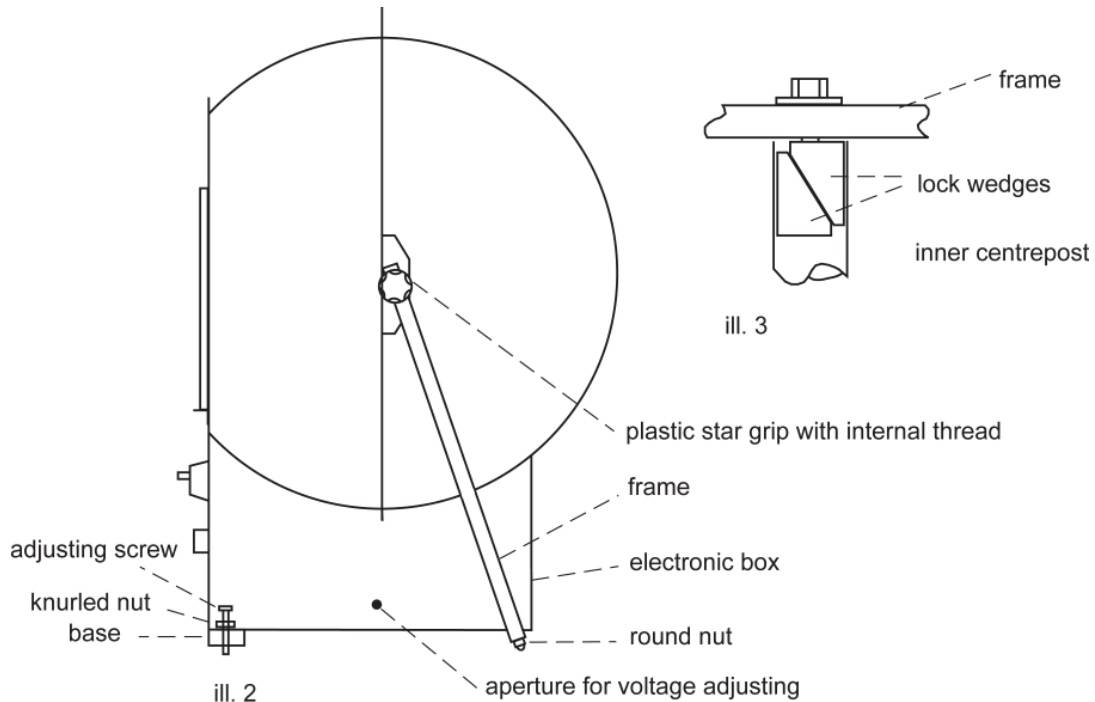

### 1. Table model

To set up the table model the frame must be fixed to the respective bolts at the sides of the sphere by means of two plastic star grips with internal threads. Then swing frame backwards (until it touches the electronic box). Then the base must be mounted with two screws at the front of the electronic box and the adjusting screws in the base have to be adjusted and fixed by knurled nuts. Then the illuminator sits on three points (the two screws and the round nut fixed on the frame). The adjusting screws enable an exact leveling of the device.

### 2. Stand model

When the illuminator is used together with the tripod remove the frame first. Then take the round nut off the frame. Now lock wedges can be screwed loosely into the center position. The outer center position of the tripod is very short when folded and ends at the bottom of the guiding ring. Open legs of tripod and lock outer center position. Put fixation of inner center position on outer center position and lock with the screws. Then adjust and lock inner center position into the right height and insert the frame with the lock wedges. Tighten screw at the frame (see ill. 3). Please, note that the bevelled edges of the lock wedges have to be aligned parallelly with the frame (for a clearer demonstration this was not respected in ill. 3). Then fit in illuminator.



### Technical information on the light

When inserting a transparency the luxmeter indicates slightly different values. This is due to light being reflected from the transparency to the inside of the sphere. Since this happens every time the illuminator is in normal use the luxmeter was adjusted in our factory while a transparency (without specific image) was inserted.

The light source is a halogen lamp of 100W which is inserted in the box underneath the sphere. The lamp aperture inside the sphere is screened towards the measuring window by a multi-folded metal plate. This screen plate prevents a direct radiation to the transparency window and reflects the light to the back of the sphere. Shadows inside the sphere that are caused by the screen plate are outside the window area and do not impair the uniformity of the lighted area.

The light density can be regulated by a control knob in a ratio of 1:100. An LCD- display at the front panel shows the light intensity measured by a digital photometer. It can be regulated by means of a mechanical shutter. When turning the knob to the left the shutter is shifted between the lamp and the sphere aperture. By using such a mechanical shutter the color temperature of the light remains constant.

The photometer that measures the light density in the LE6 is a luxmeter which originally was developed for light engineering and scientific use. It therefore also enables the measurement of light intensities in a klx range which can not be reached by the LE6. Measurement range are:

A	0.000	....	1.999	lx	For the usual measurements of TV cameras at 2000 lx we recommend to use range E.
B	00.00	....	19.99	lx	
C	000.0	....	199.99	lx	
D	0.000	....	1.999	klx	
E	00.00	....	19.99	klx	
F	000.0	....	199.9	klx	

Indeed it would be physically correct to measure the light density of the device in  $\text{cd}/\text{m}^2$ . But as for TV cameras the measuring specifications are usually given for a defined light intensity (lx), measurements with the LE6 are given only in lux.

The interior of the sphere is coated with a specific sphere coating showing a high degree of color neutrality in the relevant spectrum (> 95%); see ill. 3.

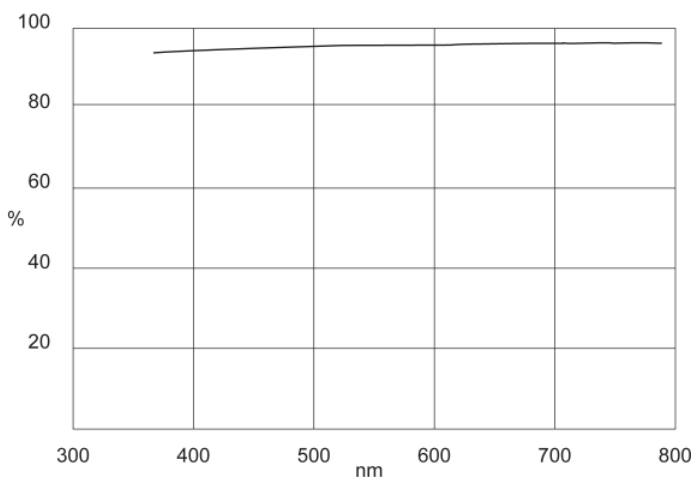

ill. 3 spectral remission of sphere colour

When delivered, the device is adjusted to a color temperature of 3250K in order to compensate the reduction of the color temperature cause by the film material of the test transparencies.



## Technical data

Serial no.	
Light source	Halogen (12V/ 100W) Osram HLX 64625 or similar
Durability of light source	90h *
Max. light density (continuously adjustable 1:100)	
Max. unevenness	4%
Color temperature	
Mains voltage	100-230V, 50-60Hz
Stabilization factor	> 1%
Power input	approx. 80W
Dimensions (w x h x d)	630x710x500mm
Weight	11kg

The color temperature can be regulated by altering the voltage of the lamp. The voltage of the lamp is shown on the LCD panel. To alter the voltage insert a small screwdriver into the little hole in the middle of the right side of the electronic box. Turning right increases the voltage, turning left decreases the voltage. Please take into account that changing the voltage also leads to a changing of the maximum light density.\*

\* see datasheet LE6 lamp

## Important information

When switching on it takes 3-4 seconds before the turns on. This is normal.

In order to impair the light intensity of the sphere as little as possible we intentionally did not insert a diffusing pane into the transparency window. To protect the interior of the sphere from dust we recommend to have a transparency always inserted in the inner slot. In addition to the slot for the test transparency there is a second slot that may take a conversion resp. neutral density filter. When using daylight filters it must be considered that the remaining light density may no longer meet the requirements of accurate measurements. Since the illuminator is adjustable, ND-filters have to be used only for special purposes (e.g. low-light cameras). When measuring with very low light intensity, i.e. when the shutter is almost closed, we recommend to switch on the fan and to insert the test transparency into the outer slot in order to guarantee sufficient ventilation. To safeguard the halogen lamp we advise you to switch off the light after the measurement.

## Maintenance

From time to time the halogen lamp has to be replaced

1. Interrupt mains supply.
2. Pull out carefully the sliding box with the electronics at its handle (it is hold by a spring lock).
3. Disconnect plug connection between photometer and measuring head.
4. Take out used halogen lamp and insert vertically into the ceramic socket both pins of the new lamp until stop. **Caution: Do not touch the halogen lamp with uncovered hands.**
5. Now proceed in reverse order: insert the sliding box (and fix safety screws).